

EFFECT OF HYDROGEN ADDITION AT DIFFERENT LEVELS ON EMISSIONS AND PERFORMANCE OF A DIESEL ENGINE

Y. Karagöz^{1,*}

ABSTRACT

The ratio of diesel vehicles in vehicle park and also the number of diesel vehicles sharply increase in the world. Advantages of diesel engines can be stated as high efficiency, low fuel consumption etc., on the other hand high amount of oxides of nitrogen caused by high compression ratio of diesel engines should be noted as its disadvantage. Moreover, a high amount of smoke emission is formed due to combustion characteristics of diesel engines. Both NO_x and smoke are really hazardous for the environment. Stringent emission regulations force diesel engines to exhaust less NO_x and smoke emissions. Thus, diesel engines require advanced after - treatment systems. The catalyst materials in after - treatment systems are really expensive. In this study, different levels of hydrogen [0%, 40% and 75%] on energy basis of total fuel were introduced into intake manifold of engine. Brake thermal efficiency of the engine improved with increasing percentage of hydrogen. CO, THC and smoke emissions are significantly decreased by using hydrogen as additional fuel. Especially, a novel decrease on smoke emission [up to 70.7%] is obtained. However, particularly during 75% hydrogen addition, the dramatic increase in NO_x emissions could not be prevented.

Keywords: CI Engine, Diesel, Hydrogen, NO_x, Smoke, Performance, Emissions

INTRODUCTION

Increasing energy demand in the world, decreasing oil reserves, and stringent emission regulation on transportation stimulate researchers to use environment-friendly, clean and alternative fuels on vehicles. In white Paper Report which was published by European Union Commission, 60% reduction in greenhouse gas emissions in 2050 is aimed [1]. Despite a lot of measures taken by the European Union, renewable energy consumption level could not reach target value between 2010 and 2011 [1]. As known, diesel engines have to be used in transportation sector at least in the near future, however they emit oxides of nitrogen and particulate matter [2-4]. According to Air Quality Report in Europe, NO_x emission values are 42% higher than from limit values in emission measurement points in 2011 [1]. Moreover, the particulate matter emission values are 43% higher than limit points [1]. The after - treatment equipment prices are really high due to costs of catalyst materials. Consequently, some researchers start to use alternative fuels such as LPG, CNG, LNG, biogas, and ethanol [5-15]. Hydrogen is a conspicuous and promising alternative fuel in the world [15]. The battery capacity is insufficient, for this reason it is impossible to use electrical vehicle or hybrid vehicle in the near future [16]. Using alternative, clean gas fuels such as hydrogen in diesel engines may be a solution in this period [17].

Some researchers [18, 19] had studied hydrogen in homogenously filled compression ignition engines [HCCI], but because of combustion stability it is impossible to use them in the real world. Some researchers used hydrogen in spark ignition engines [20-23], however the problems such as power loss, combustion stability problems, backfiring etc. are observed.

Some researchers studied in Otto engines and used hydrogen and oxygen as supplementary fuel [24]. Also, Karagoz et al. [24] sent water into the engine and they found that the engine performance and emissions improved except for NO_x.

Some researchers worked with natural gas and hydrogen blends [25, 26]. Huang et al. [27] studied about cyclic variations in SI engine fuelled with different levels of natural gas and hydrogen blends. On the other hand, some researchers [28] studied about compressed bio gas-diesel fuel blend and they obtained that the emission values improved with gas fuel addition.

This paper was recommended for publication in revised form by Regional Editor Bekir Yilbas

¹Automotive Division, Department of Mechanical Engineering, Mechanical Engineering Faculty, Yıldız Technical University, Yıldız, Besiktas, Istanbul, 34349, Turkey

**E-mail address: ykaragoz@yildiz.edu.tr*

Manuscript Received 28 July 2017, Accepted 8 September 2017

Despite superior performance of diesel engines, they suffer from NO_x and particulate matter emissions [28, 29]. On the other hand, emission regulations force to use advanced after - treatment systems to limit NO_x and particulate matter emissions but prices of after - treatment systems are expensive. Using alternative gas fuels like hydrogen in diesel engines will be an alternative to control emissions [17]. Hydrogen has 576°C inflammation temperature, for this reason it will be easily used in diesel engines with diesel fuel [31]. In order to ignite combustible mixture, an energy source is required [32]. Ikegami et al. [33] used glow-plugs to heat combustible mixture. Antunes et al. [31] heated intake air to ensure ignition stability.

Using pilot diesel fuel as ignition source and hydrogen port fuel injection is the most common and reliable method [34-36]. Since, high pressure direct hydrogen injectors take place in the market, direct hydrogen injector into the cylinder is not commercially possible. Also, continuous hydrogen injection is not reliable since backfiring, pre-ignition and other combustion problems in the engines may occur [2]. For this reason, injection of hydrogen using gas injectors and an electronic control unit is the most suitable method.

The works about using hydrogen in compression ignition engines are given below. Horng-Wen Wu and Zhan-Yi Wu [36] introduced 0% to 20% hydrogen on energy basis at 1800 rpm constant engine speed. According to their obtained results, the thermal efficiency, CO and soot improved with hydrogen addition. Pan et al. [35] experimentally studied on two stroke, supercharged MTU 12V diesel engine. They introduced 0 slpm, 22 slpm and 220 slpm hydrogen versus engine loads. They obtained that CO and particulate matter emissions decrease with increasing amount of hydrogen. Bika et al. [17] studied on a supercharged, Volkswagen diesel engine at 1700 rpm engine speed with 0% and 40% hydrogen addition and at different engine loads. They obtained that the NO_x emissions unchanged, particulate matter emissions did not change. Miyamoto et al. [16] sent up to 16% hydrogen on volume basis in a diesel engine. They obtained that NO_x emissions were decreased while HC emission did not change. Hosseini and Ahmadi [37] studied on a heavy duty type diesel engine using hydrogen-diesel dual fuel and they found that the emissions of NO_x, UHC, soot, CO and CO₂ are reduced with hydrogen addition. Talibi et al. [38] studied diesel-hydrogen dual fuel using high EGR levels, and they found that particulate mass decreased up to 75%.

Many studies have been done on hydrogen addition in compression ignition engines, but a few studies can be found about effect of different levels of hydrogen addition. Especially, effect of wide range of hydrogen energy fraction from 0% to 75% has not been investigated. For this reason, in this study different levels of hydrogen [0%, 40% and 75% on energy basis] were experimentally investigated at 1300 rpm engine speed at full [100%] engine load.

TESTING SET

Schematic illustration of the testing set is given in Figure 1. A single cylinder, four stroke, naturally aspirated engine was converted into common-rail diesel fuel system. Instead of mechanical injector, an electromagnetic injector was used. The pulverization angle as 145° is same for both injectors. A high pressure diesel fuel pump and rail were used. 10⁸ Pa rail pressure was used as constant during tests. Diesel fuel is suitable for EN590 standart. A high pressure hydrogen tank was placed outside of the laboratory. The hydrogen has a purtiy of 99.99%. An ECU was developed to control both hydrogen injector and diesel injector. A miniature oval gear type flow meter was installed to measure diesel fuel. A mass flow meter was installed on hydrogen line. Thermocouples were installed to measure engine cooling water temperature, engine oil temperature and exhaust gas temperature. A usb type NI6215 data acquisition card was used and using LabView software an interface was developed to measure diesel flow rate, hydrogen flow rate, AVL Dicom 4000 emssion analyser and AVL 415S smoke meter.

Diesel Engine and The Engine Dynamometer

The technical specs of the diesel engine can be given as follows: single-cylinder, 1.16 L, naturally aspirated, four-stroke, direct injection. The diesel engine was developed by Erin motor and Yildiz Technical University. An water cooling type Eddy current dynamometer which has 40 kW engine loading capacity was used to load test engine in Yildiz Technical University. The technical properties of diesel engine and engine dynamometer were shown in Table 1. According to technical specifications, the maximum power of the engine is 18 kW at 2700 rpm engine speed. The test rig was adapted to operate the diesel engine with hydrogen as fuel

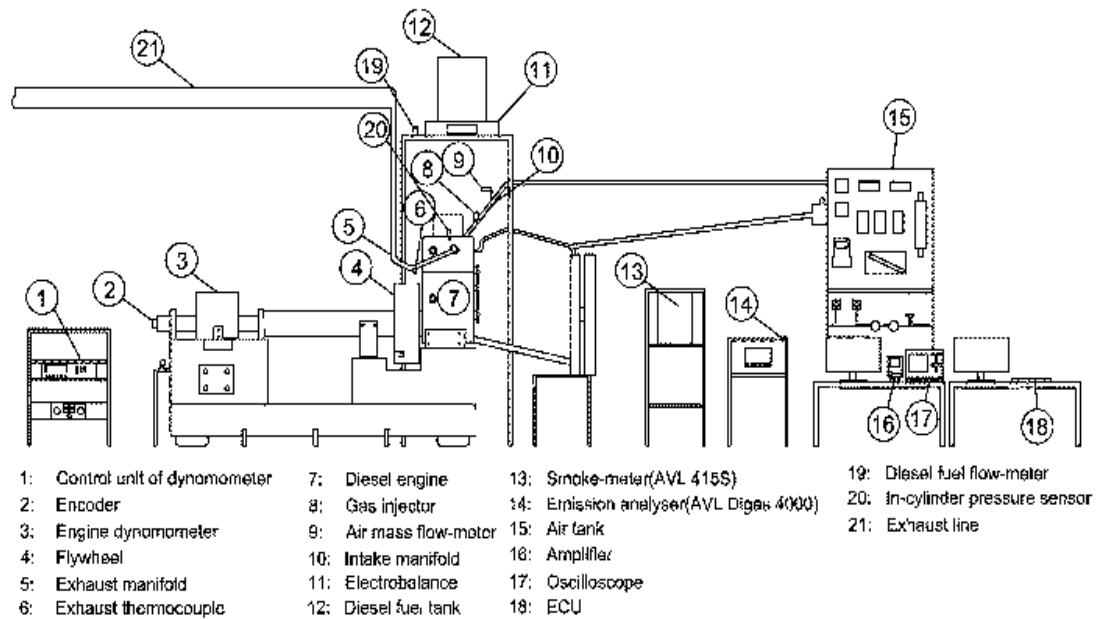

Figure 1. Schematics of the testing set

Table 1. Technical properties of the engine dyno and diesel engine

Engine manufacturer	Erin-motor engine
Aspiration	Natural
Maximum power	18 kW@2700 rpm
Number of cylinders	1
Bore × stroke [mm]	108 × 127
Cylinder volume [cm ³]	1163
Compression ratio	14.7
Speed range min-max [rpm]	800 – 2700
Number of intake & exhaust valves	2 & 2
Cooling	Water cooled
Dyno type & power [kW]	Eddy current & 40

Gas Fuel Line

Hydrogen has unique properties. The auto-ignition temperature of hydrogen is 858 K [27]. The diffusion coefficient of hydrogen is 0.61 cm²/s [27]. The adiabatic flame speed of hydrogen is 237 cm/s [27]. Figure 2 shows schematics of hydrogen fuel line. A high pressure tank was used to store hydrogen which has purity above %99.99. A double stage hydrogen pressure regulator was installed to reduce hydrogen pressure. To prevent backfire, a solenoid shut-off valve was used. A quick-connect type connection which operates also as a check valve is installed just before the diesel engine. Moreover, a relief-valve was installed to prevent over-pressure on the line. A second pressure regulator which is line type regulator was set to accurately adjust the pressure line. An electromagnetic hydrogen gas injector was installed to the diesel engine manifold.

The Engine Ecu

Figure 3 shows the schematics of the engine ECU [electronic control unit]. The engine ECU was developed in Yıldız Technical University and it operates with a microcontroller. The developed ECU can both control hydrogen injector and diesel injector. An incremental type encoder was installed on the engine. Two different signals one of which is zero signal determines piston position, and the other one generates 360 pulses/revolution were used to control injectors [diesel and hydrogen] with ECU. Arduino-Due cards were used to change injection advance and injection duration during the engine running. 12 Volt DC power supply was used

during injectors were controlled. Since, the injection parameters directly affect the engine performance and emissions as proved by some reasearchers [39], using ECU to control injectors is very important. The diesel injection advance was adjusted to 28° before top dead center.

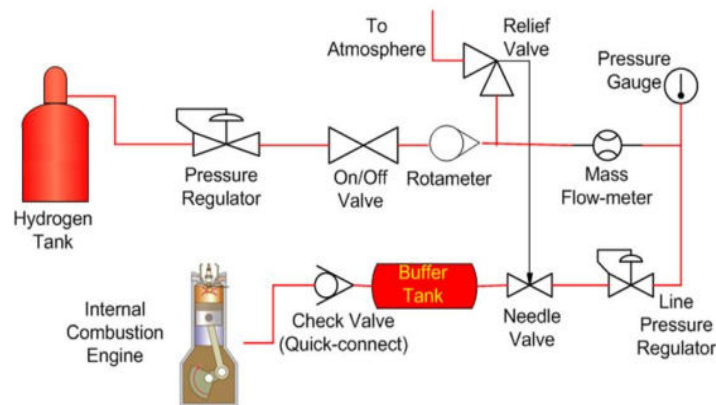

Figure 2. Schematics of the hydrogen line

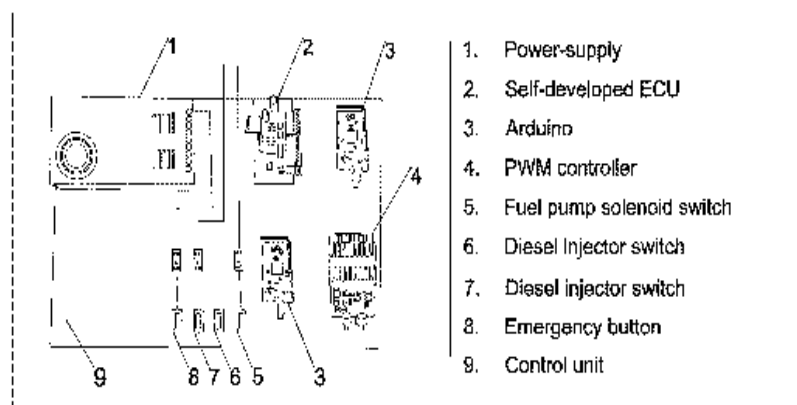

Figure 3. Schematics the engine ECU

Exhaust Gas Emission Measurement

Using AVL Digas 4000 exhaust analyser CO, THC and NO_x emissions were measured. To measure smoke emission, AVL 415S smoke analyser was used. AVL Dicom 4000 measures CO and THC emissions as %volume, NO_x emissions as ppm. AVL 415S measures as FSN or mg/m³. Since the engine torque and the engine speed are kept constant during test, the emission units were not converted into brake specific emissions.

The Engine Operation

The test engine was opareded according to ESC [European Stationary Cycle] at 1300 rpm engine speed. 1300 rpm is equal to A engine speed operation point for the test engine. Different levels of hydrogen energy fraction [0%, %40 and %75] were tested. 0% hydrogen energy level means neat diesel fuel operation. All tests were performed at full [100%] engine load condition. The test engine is warmed up until it reaches the regime temperature. The diesel fuel injected at 28° before top dead centre [BTDC]. The hydrogen fuel was injected at top dead centre [TDC]. The test conditions were given in Table 2. The engine brake torque was kept constant as 72 Nm at 1300 rpm engine speed. The engine brake power value is also constant as 9.8 kW in all hydrogen energy values. The brake specific fuel consumption, THC, CO, NO_x and smoke values are experimentally investigated with different values of hydrogen addition at 72 Nm brake engine torque and 1300 rpm engine speed. During experimental tests, any combustion problem like knock, backfiiring, preignition did not occur. The accuracies and uncertainty values are given in Table 3.

Table 2. The summary of test conditions.

Engine brake torque	Engine speed	Start of diesel injection	Hydrogen energy fraction	Diesel energy fraction
72 Nm	1300 rpm	28°BTDC	0%	100%
72 Nm	1300 rpm	28°BTDC	40%	60%
72 Nm	1300 rpm	28°BTDC	75%	25%

Table 3. Measurement accuracies and calculated uncertainties

Parameter	Device	Accuracy
Engine torque	Load cell	±0.05 Nm
Engine speed	Incremental Encoder	±5 rpm
Cylinder pressure	Kistler 6253C	±0.5 %
Diesel flow rate	Biotech VZS-005	±1 % [of reading]
NG flow rate	New-Flow TMF	±1 % [F.S.]
CO	AVL DiCom 4000	0.01 % Vol.
THC	AVL DiCom 4000	1 ppm
NO _x	AVL DiCom 4000	1 ppm
Smoke	AVL 415S	0.4 % Vol.
Calculated results		Uncertainty value
Engine power		±0.28 %
Thermal efficiency		±1.10 ÷ 1.43 % [0% ÷ 75% hydrogen]

RESULTS AND DISCUSSION

In this study, the engine performance [brake thermal efficiency] and emissions [CO, THC, NO_x and smoke] were experimentally tested at full engine load and 1300 rpm constant engine speed. The test engine and test cell were modified to operate with hydrogen. The hydrogen fuel was injected into the test engine intake manifold using gas injector. An electromagnetic diesel injector was used to send diesel fuel into the engine. A self developed hybrid ECU which controls both diesel and gas injectors was used to operate the engine in dual fuel mode. Different levels of hydrogen energy fraction [0%, 40% and 75%] were tested.

The brake thermal efficiency means the proportion of the brake power and fuel energy consumption. It shows how much energy is converted into useful energy [40]. The obtained brake thermal efficiency values depending on hydrogen energy fraction were given in Figure 4. The brake thermal efficiency values were improved with increased level of hydrogen energy fraction. The brake thermal efficiency values are %23.8, %24.1 and %24.3 when hydrogen level is 0%, 40% and 75%, respectively. The improvement in brake thermal efficiency is 1.26% and 2.1%, respectively according to neat diesel fuel operation with 40% and %75 hydrogen addition. The flame speed of hydrogen is faster than diesel. Moreover, the diffusion coefficient of hydrogen is higher than other fuels. The homogeneity of air-fuel mixture improves with hydrogen addition. Also, the combustion efficiency of combustible mixture increases due to high flame speed of hydrogen. Thus, the combustion process approaches to ideal constant volume combustion.

CO is a harmful emission and released from internal combustion engines and it is a conclusion of inefficient combustion of petroleum based fuels [41]. The basic reason of CO emission is lack of oxygen during combustion. The effect of hydrogen addition on CO emission is shown in Figure 5. The CO emission values are 0.28 %vol., 0.21 %vol. and 0.11 %vol., respectively with 0%, 40% and 75% hydrogen addition.

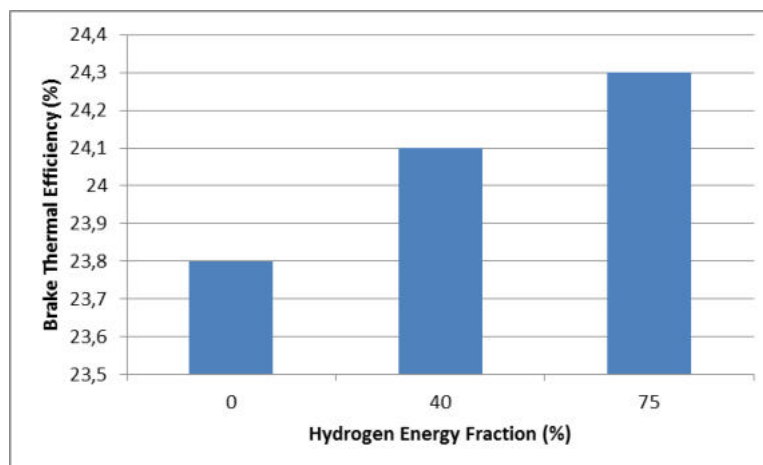

Figure 4. Effect of different amount of hydrogen addition on brake thermal efficiency

The improvement on CO emissions is 25% and 60.7% respectively, according to neat diesel with 40% and 75% hydrogen addition. The hydrogen fuel does not contain any carbon atom. On the other hand, the total carbon/hydrogen ratio decreases with increasing amount of hydrogen. Also, the combustion efficiency increases with hydrogen addition due to high flame speed and high diffusion coefficient properties of hydrogen.

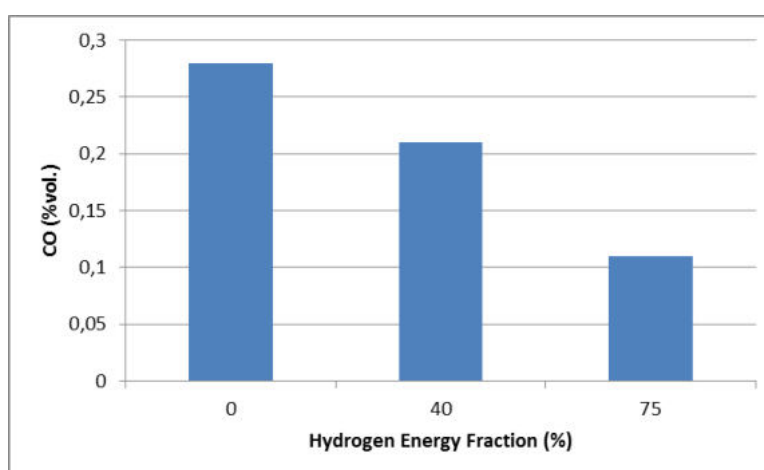

Figure 5. Effect of different amount of hydrogen addition on CO emissions

Hydrocarbons are generated from incomplete combustion of hydrocarbon based fuels. The exhausted unburned hydrocarbons from internal combustion engines is called as total hydrocarbons [THC] [42]. The total hydrocarbon values depending on different levels of hydrogen addition is given in Figure 6. The total hydrocarbon values are 23 ppm, 16 ppm and 8 ppm with 0%, 40% and 75% hydrogen addition, respectively. The improvement in THC emission according to neat diesel fuel is 30.4% and 60.2% with 40% and 75% hydrogen addition respectively. Oxides of nitrogen [NO_x] are composed of nitrogen monoxide [NO] and nitrogen dioxide [NO₂]. The oxides of nitrogen are really harmful for the environment and human health. Two basic mechanisms explain nitrogen monoxide formation which are thermal mechanism [Zeldovich mechanism] and prompt mechanism [Fenimore mechanism].

The NO formation depends on in-cylinder temperature and oxygen concentration. In the combustion process of compression ignition engines, thermal mechanism has a domination on oxides of nitrogen formation [43, 44].

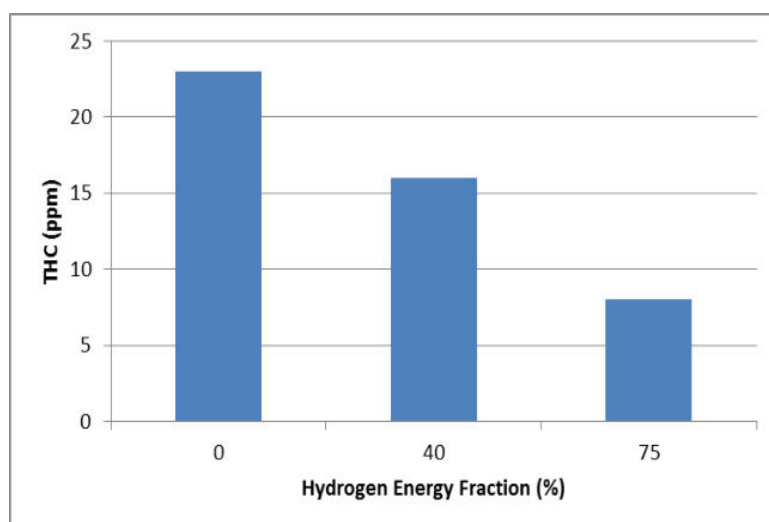

Figure 6. Effect of different amount of hydrogen addition on THC emission

Figure 7 shows the oxides of nitrogen emission values depending on different level of hydrogen addition. According to obtained results, the oxides of nitrogen emissions dramatically increase with hydrogen addition. The NO_x values are 2740 ppm, 2970 ppm and 3970 ppm with 0%, 40% and 75% hydrogen addition. The increase in NO_x emissions are 8.4% and 44.9%, respectively with 40% and 75% hydrogen addition according to neat diesel. Since, adiabatic flame temperature is higher than other petroleum fuel, in-cylinder temperature increases with hydrogen addition. Also, high in-cylinder pressure increases with hydrogen addition due to high flame speed of hydrogen. Also, the combustion duration shortened with hydrogen addition. As a result, NO_x emissions dramatically increase with hydrogen addition.

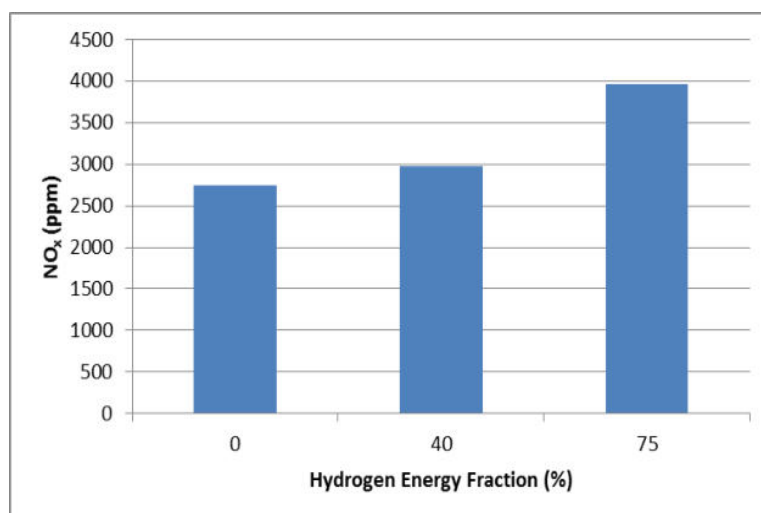

Figure 7. Effect of different amount of hydrogen addition on NO_x emission

Diesel smoke emission is formed from carbonaceous materials. Carbonaceous materials are generated due to incomplete combustion and lack of oxygen [42]. Figure 8 shows smoke emission values depending on different level of hydrogen addition. The smoke emission values are 0.58 FSN, 0.47FSN and 0.17FSN with 0%, 40% and 75% hydrogen addition, respectively. The improvement in smoke emission values is 18.9% and 70.7% regarding to neat diesel with 40% and 75% hydrogen addition, respectively. Hydrogen does not contain any carbon atoms. Moreover, it improves combustion efficiency. Furthermore, it improves the homogeneity of combustible mixture. Also, total carbon/hydrogen ratio of fuel will decrease with hydrogen fuel addition. Thus, smoke emission decreases with increasing amount of hydrogen fuel.

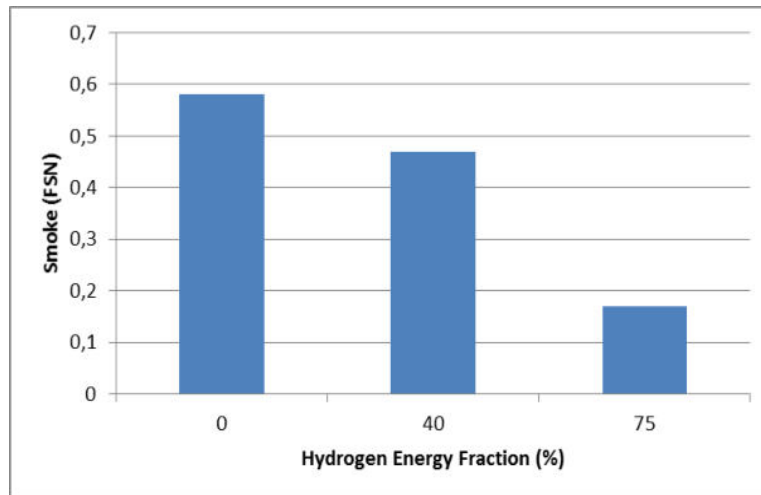

Figure 8. Effect of different amount of hydrogen addition on smoke emission

CONCLUSION

Engine values regarding brake thermal efficiency, and emissions of CO, THC, smoke and NO_x were experimentally investigated in this work. Tests were performed in a four stroke, water cooled, naturally aspirated, single cylinder diesel engine at 1300 rpm constant engine speed and full engine load. Different levels of hydrogen [0%, 40% and 75% by energy content] were experimentally tested in the compression ignition test engine.

Acquired results are given below:

- The brake thermal efficiency increased by 1.26% and 2.1%, respectively with addition of 40% and 75% hydrogen compared to neat diesel fuel.
- CO emissions decreased by 25% and 60.7%, respectively with 40% and 75% hydrogen addition as energy content compared to only diesel fuel.
- THC emissions improved by 30.4% and 60.2% with 40% and 75% hydrogen addition.
- A dramatic increase of 8.4% and 44.9% is obtained in NO_x emissions respectively with 40% and 75% hydrogen addition compared to only diesel fuel.
- A novel improvement of 18.9% and 70.7%, respectively is observed in smoke emissions with 40% and 75% hydrogen addition.

ACKNOWLEDGEMENT

This research was supported by Tübitak (Scientific and Technological Research Council of Turkey) with 1512 project. Project Number: 2150175. The author is also indebted to Şahin Metal A.Ş. and Erin Motor for test apparatus and equipment donation.

NOMENCLATURE

CI	Compression ignition
CNG	Compressed natural gas
CO	Carbon monoxide
CO ₂	Carbon dioxide
DPF	Diesel particulate filter
ECU	Electronic control unit
HC	Hydrocarbons
HCCI	Homogenous charge compression ignition
ICEs	Internal combustion engines
LNG	Liquefied natural gas
LPG	Liquefied petroleum gas
NO _x	Oxides of nitrogen

SCR	Selective catalytic reduction
SI	Spark ignition
THC	Total unburned hydrocarbons
USB	Universal serial bus

REFERENCES

- [1] European Environment Agency [EEA]. (2013). Trends and projections in Europe 2013: Tracking progress towards Europe's climate and energy targets until 2020. Report No 10/2013.
- [2] Köse, H., Ciniviz, M. (2013). An experimental investigation of effect on diesel engine performance and exhaust emissions of addition at dual fuel mode of hydrogen. *Fuel Processing Technology*, 114, 26–34.
- [3] Liu, Y., Yang, J., Sun, J., Zhu, A., Zhou, Q. A (2011). Phenomenological model for prediction auto-ignition and soot formation of turbulent diffusion combustion in a high pressure common rail diesel engine. *International Journal of Hydrogen Energy*, 4, 894-912.
- [4] Nieminen, J., D'Souza, N., Dincer, I. (2010). Comparative combustion characteristics of gasoline and hydrogen fuelled ICEs. *International Journal of Hydrogen Energy*, 35, 5114-5123.
- [5] Lata, D.B., Misra, A., Medhekar, S. (2012). Effect of hydrogen and LPG addition on the efficiency and emissions of a dual fuel diesel engine. *International Journal of Hydrogen Energy*, 37, 6084-6096.
- [6] Lata, D.B., Misra, A., Medhekar, S. (2011). Investigations on the combustion parameters of a dual fuel diesel engine with hydrogen and LPG as secondary fuels. *International Journal of Hydrogen Energy*, 36, 13808-13819.
- [7] He, Y., Mab, F., Deng, J., Shao, Y., Jian, X. (2012). Reducing the idle speed of an SI CNG engine fueled by HCNG with high hydrogen ratio. *Int J Hydrogen Energy*, 37, 8698-8703.
- [8] Mohammed, S.E., Baharom, M.B., Aziz, A.R.A., Firmansyah. (2011). The effects of fuel-injection timing at medium injection pressure on the engine characteristics and emissions of a CNG-DI engine fueled by a small amount of hydrogen in CNG. *International Journal of Hydrogen Energy*, 36, 11997-12006.
- [9] Xin, Z., Jian, X., Shizhuo, Z., Xiaosen, H., Jianhua, L. (2013). The experimental study on cyclic variation in a spark ignited engine fueled with biogas and hydrogen blends. *International Journal of Hydrogen Energy*, 38, 11164-11168.
- [10] Park, C., Park, S., Lee, Y., Kim, C., Lee, S., Moriyoshi, Y. (2011). Performance and emission characteristics of a SI engine fueled by low calorific biogas blended with hydrogen. *International Journal of Hydrogen Energy*, 36, 10080-88.
- [11] Greenwood, J.B., Erickson, P.A., Hwang, J., Jordan, E.A. (2014). Experimental results of hydrogen enrichment of ethanol in an ultra-lean internal combustion engine *International Journal of Hydrogen Energy*, 39, 12980-90.
- [12] Ji, C., Liu, X., Wang, S., Gao, B., Yang, J. (2014). A laminar burning velocity correlation for combustion simulation of hydrogen-enriched ethanol engines. *Fuel*, 133, 139–142.
- [13] Biffiger, H., Soltic, P. (2015). Effects of split port/direct injection of methane and hydrogen in a spark ignition engine. *International Journal of Hydrogen Energy*, 40, 1994-2003.
- [14] Shivaprasad, K.V., Raviteja, S., Chitragar, P., Kumar, G.N. (2014). Experimental investigation of the effect of hydrogen addition on combustion performance and emissions characteristics of a spark ignition high speed gasoline engine. *Procedia Technology*, 14, 141–148.
- [15] Saravanan, N., Nagarajan, G. (2009). Experimental investigation on performance and emission characteristics of dual fuel DI diesel engine with hydrogen fuel. SAE Paper No. 2009-26-032.
- [16] Miyamoto, T., Mikami, M., Kojima, N., Kabashima, H., Urata, Y. (2009). Effect of hydrogen fraction in intake mixture on combustion and exhaust emission characteristics of a diesel engine. SAE Paper No. 2009-24-0086.
- [17] Bika, A.S., Franklin, L.M., Kittelson, D.B. (2008). Emissions effects of hydrogen as a supplemental fuel with diesel and biodiesel. SAE Paper No. 2008-01-0648.
- [18] Gomes-Antunes, J.M., Mikalsen, R., Roskilly, (2008). A.P. An investigation f hydrogen fuelled HCCI engine performance and operation. *International Journal of Hydrogen Energy*, 33, 5823–5828.
- [19] Szwaja, S., Grab-Rogalinski, K., (2009). Hydrogen combustion in a compression ignition diesel engine. *International Journal of Hydrogen Energy*, 34, 4413–4421.

- [20] Sopena, C., Dieguez, P.M., Sainz, D., Urroz, J.C., Guelbenzu, E., Gandia, L.M., (2010). Conversion of a commercial spark ignition engine to run on hydrogen: Performance comparison using hydrogen and gasoline. *International Journal of Hydrogen Energy*, 35, 1420-1429.
- [21] Ji, C., Wang, S. (2009). Effect of hydrogen addition on the idle performance of a spark ignited gasoline engine at stoichiometric condition. *International Journal of Hydrogen Energy*, 34, 3546-3556.
- [22] Wang, S., Ji, C., Zhang, M., Zhang, B. (2010). Reducing the idle speed of a spark-ignited gasoline engine with hydrogen addition. *International Journal of Hydrogen Energy*, 35 10580-88.
- [23] Andrea, T.D., Henshaw, P.F., Ting, S.K. (2004). The addition of hydrogen to a gasoline fuelled SI engine. *International Journal of Hydrogen Energy*, 29, 1541-52.
- [24] Karagöz, Y., Yüksek, L., Sandalcı, T., Dalkılıç, A.S. (2015). An experimental investigation on the performance characteristics of a hydroxygen enriched gasoline engine with water injection. *International Journal of Hydrogen Energy*, 40, 692-702.
- [25] Hu, E., Huang, Z., Liu, B., Zheng, J., Gu, X., Huang B. (2009). Experimental investigation on performance and emissions of a spark-ignition engine fuelled with natural gas-hydrogen blends combined with EGR. I *International Journal of Hydrogen Energy*, 34, 528-539.
- [26] Hu, E., Huang, Z., Liu, B., Zheng, J., Gu, X. (2009). Experimental study on combustion characteristics of a spark-ignition engine fuelled with natural gas-hydrogen blends combining with EGR. *International Journal of Hydrogen Energy*, 34, 1035-1044.
- [27] Huang, B., Hu, E., Huang, Z., Zheng, J., Liu, B., Jiang, D. (2009). Cycle-by-cycle variations in a spark ignition engine fueled with natural gas-hydrogen blends combined with EGR. *International Journal of Hydrogen Energy*, 34, 8405-8414.
- [28] Köten, H., Yilmaz, M., Gül, M.Z. (2014). Compressed bio gas [CBG]-diesel dual fuel engine optimization study for ultra-low emission”, *JAME*.
- [29] Heywood, J.B. (1988). *Internal Combustion Engine Fundamentals*. McGraw Hill Inc. New York, USA.
- [30] Miyamoto, T., Hasegawa, H., Mikami, M., Kojima, N., Kabashima, H., Urata, Y. (2011). Effect of hydrogen addition to intake gas on combustion and exhaust emission characteristics of a diesel engine. *International Journal of Hydrogen Energy*, 36, 13138-13149.
- [31] Bose, P.K., Maji, D. (2009). An experimental investigation on engine performance and emissions of a single cylinder diesel engine using hydrogen as inducted fuel and diesel as injected fuel with exhaust gas recirculation. *International Journal of Hydrogen Energy*, 34, 4847– 4854.
- [32] Gomes-Antunes, J.M., Mikalsen, R., Roskilly, A.P. (2009). An experimental study of a direct injection compression ignition hydrogen engine. *International Journal of Hydrogen Energy*, 34, 6516–6522.
- [33] Ikegami, M., Miwa, M., Shioji, M. A (1982). Study on hydrogen fuelled compression ignition engines. *International Journal of Hydrogen Energy*, 7, 341-353.
- [34] Christodoulou, F., Megaritis, A. (2013). Experimental investigation of the effects of separate hydrogen and nitrogen addition on the emissions and combustion of a diesel engine. *International Journal of Hydrogen Energy*, 38, 10126-10140.
- [35] Pan, H., Pournazeri, S., Princevac, M., Miller, J.W., Mahalingam, S., Khan, M.Y., Jayaram, V., Welch, W.A. (2014). Effect of hydrogen addition on criteria and greenhouse gas emissions for a marine diesel engine. *International Journal of Hydrogen Energy*, 39, 11336-11345.
- [36] Wu, H.W., Wu, Z.Y. (2012). Investigation on combustion characteristics and emissions of diesel/hydrogen mixtures by using energy-share method in a diesel engine. *Applied Thermal Engineering*, 42, 154-162.
- [37] Hosseini, S.M., Ahmadi, R. (2017). Performance and emissions characteristics in the combustion of co-fuel diesel-hydrogen in a heavy duty engine. *Applied Energy*, 205, 911-925.
- [38] Talibi, M., Hellier, P., Ladommatos, N. (2017). The effect of varying EGR and intake air boost on hydrogen-diesel co-combustion in CI engines. *International Journal of Hydrogen Energy*, 42, 6369-6383.
- [39] Köten, H., Yilmaz, M., Gül, M.Z. (2012). Effects of the injection parameters and compression ratio on the emissions of a heavy duty diesel engine. 147-163.
- [40] Pulkrabek, W.W. (2004). *Engineering Fundamentals of the Internal Combustion Engine*, Prentice Hall.
- [41] Wei, L., Geng, P. (2016). A review on natural gas/diesel dual fuel combustion, emissions and performance. *Fuel Processing Technology* 142, 264–278.
- [42] Heywood, JB. (1988). *Internal Combustion Engine Fundamentals*; McGraw Hill Inc. New York, USA, 1988.

- [43] Fenimore, CP. (1971). Formation of nitric oxide in premixed hydrocarbon flames, Symp Combust, 13(1):373–380.
- [44] Stiesch, DIG. (2003). Modeling Engine Spray and Combustion Processes. Springer Berlin Heidelberg.